

# Cape Cod

Chicken Coop / Rabbit Hutch

**WARNING** For safety, remove all collars and leashes before allowing pet to enter any cage.



**THIS BOX CONTAINS THESE PARTS:**

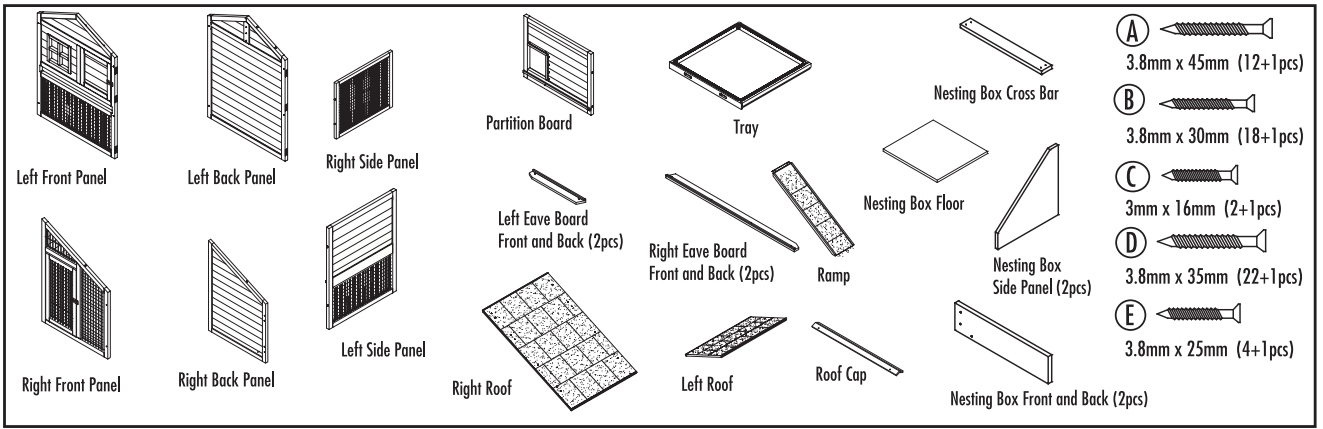

## Assembly Instructions \*Screwdriver Needed for Assembly

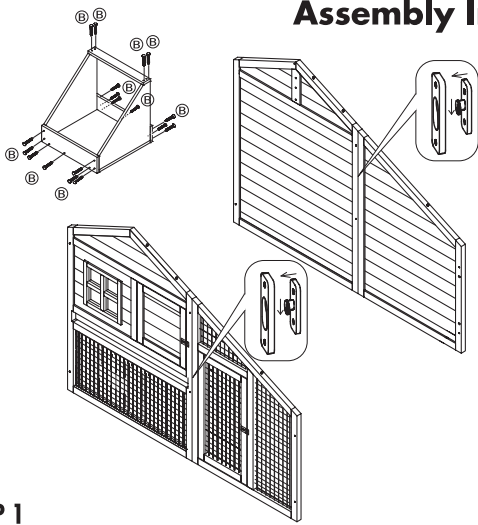

**STEP 1**  
Assemble nesting box with screws (B). Attach front right panel to front left panel by locking into place. Repeat for the back panels.

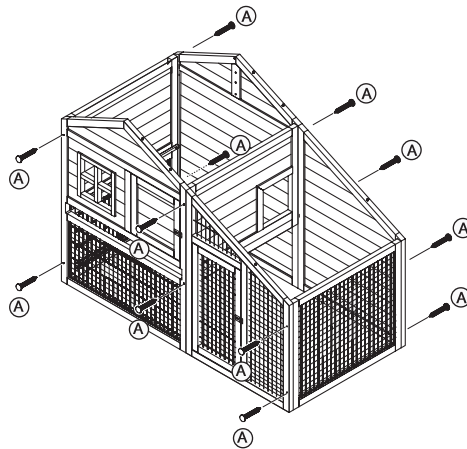

**STEP 2**  
Attach front and back panels to side panels and partition board with screws (A).

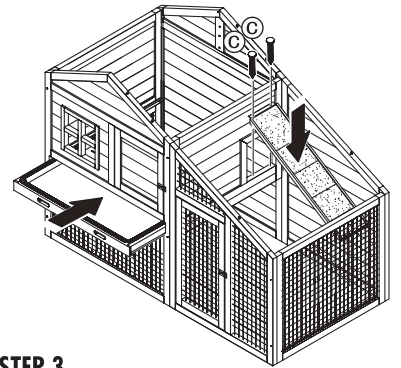

**STEP 3**  
Attach ramp with screws (C). Slide in tray.

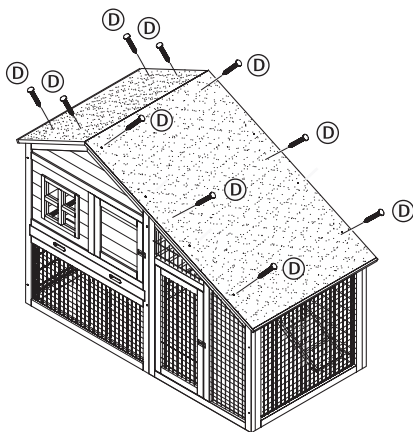

**STEP 4**  
Attach roof panels with screws (D).

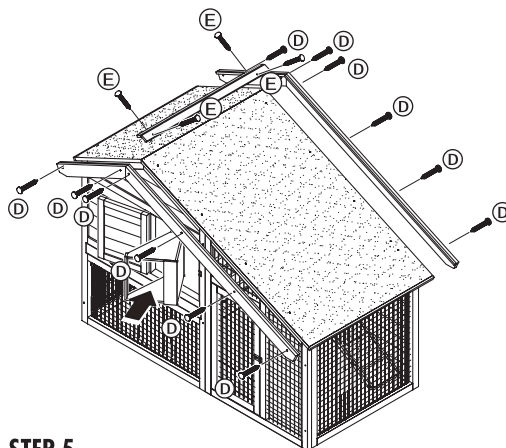

**STEP 5**  
Attach eaves to roof with screws (D). Attach roof cap with screws (E)

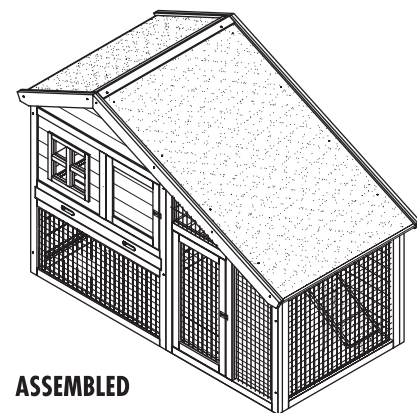

**ASSEMBLED**

Cleaning Instructions:  
Avoid Harsh Detergents.

# PRECISION PET PRODUCTS LIMITED WARRANTY

---

Precision Pet Products ("Warrantor") extends the following LIMITED WARRANTY to the original purchaser ("Purchaser") of this Pet Home ("Pet Home"):

**1. Commencement and Term.** For one (1) year from the date of original retail purchase, Warrantor will repair or replace, at its option, any part of the Pet Home which proves upon examination by Warrantor to be defective in material or workmanship. The warranty on any repaired or replacement parts is limited to the unexpired term of the original warranty.

**2. Conditions and Exceptions.** This warranty does not cover:

- a. any damage to the Pet Home caused by any animal.
- b. any damage resulting from any misuse or abuse of the Pet Home, including, but not limited to, using the Pet Home for any purpose other than confining a pet animal.
- c. any modification or alteration to, or attempted repair of, the Pet Home by Purchaser or any third party; and
- d. any defect arising or discovered more than one (1) year from the date of original retail purchase.

**3. Claim Procedure.** Any claim under this warranty must be handled according to the following procedures:

- a. If you suspect a defect in material or workmanship, call Warrantor's toll-free telephone number, 1-800-397-3167, or write to Warrantor at 2183 Fairview Rd Suite #200, Costa Mesa, California 92627, to report alleged defect to a customer service representative.
- b. Warrantor will determine if the alleged defect may be covered by this warranty. If it could be covered by this warranty, Warrantor will authorize and instruct the Purchaser how to return the Pet Home to Warrantor for examination and definitive decision concerning coverage under this warranty.
- c. Warrantor may require Purchaser to present the sales receipt or other proof of purchase prior to authorizing any return or replacement. No returns or replacements will be permitted without prior authorization from Warrantor. If a return or replacement is authorized, Purchaser may be requested to ship the item to Warrantor pursuant to Warrantor's instructions or to make the Pet Home available for pick-up by Warrantor. All shipping cost shall be the responsibility of the Purchaser.

**4. Limitation on Implied Warranties.** IMPLIED WARRANTIES, INCLUDING ANY WARRANTY OF MERCHANTABILITY AND FITNESS FOR A PARTICULAR PURPOSE, IMPOSED ON THE SALE OF THE PET HOME BY STATE LAW, ARE HEREBY EXPRESSLY LIMITED TO A TERM OF ONE (1) YEAR FROM THE DATE OF ORIGINAL RETAIL PURCHASE.

SOME STATES DO NOT ALLOW LIMITATIONS ON HOW LONG AN IMPLIED WARRANTY LASTS, SO THE ABOVE LIMITATION MAY NOT APPLY TO YOU.

**5. Disclaimer.** NO OTHER EXPRESS WARRANTY HAS BEEN MADE OR WILL BE MADE ON BEHALF OF WARRANTOR WITH RESPECT TO THE PET HOME AND/OR ITS REPAIR OR REPLACEMENT. UNDER NO CIRCUMSTANCES SHALL THE WARRANTOR BE LIABLE TO PURCHASER OR ANY OTHER PARTY OR ANY SPECIAL, INCIDENTAL OR CONSEQUENTIAL DAMAGES, WHETHER DIRECT OR INDIRECT, AND WHETHER ARISING OUT OF BREACH OF WARRANTY, BREACH OF CONTRACT, OR IN TORT.

SOME STATES DO NOT ALLOW THE EXCLUSION OR LIMITATION OF INCIDENTAL OR CONSEQUENTIAL DAMAGES, SO THE ABOVE LIMITATION MAY NOT APPLY.

**6. Grant of Legal Rights.** THIS WARRANTY GIVES YOU SPECIFIC LEGAL RIGHTS, AND YOU MAY ALSO HAVE OTHER RIGHTS WHICH VARY FROM STATE TO STATE.

If you have any questions regarding your Pet Home, please feel free to contact our Customer Service Department at 800-397-3167 or 909-801-2001 or email us at [info@precisionpet.com](mailto:info@precisionpet.com). We will be happy to assist you.